



Vertical Heat Recovery Ventilation



# Introducing – the Vertical Lossnay Range

Mitsubishi Electric has launched the next generation of Whole Home Fresh Air Heat Recovery Ventilation that does not require installation in the attic. While exposed ceilings are great from an architectural aesthetics perspective, it limits the ability to install a traditional roof based ventilation system.



## Designed for Flexibility and Convenience

The Vertical Lossnay Range is designed specifically for the New Zealand housing market and makes energy efficient, super-quiet ventilation accessible to even more homes.

Because of the slimline, vertical upright design, the Lossnay Ventilation System is not limited to an in-roof installation. With its small upright footprint it can be placed in the garage or a cupboard in the kitchen. Now whole home ventilation can be installed and integrated in the overall building design without limitations.

## Automatic Summer Bypass

Using the on-board temperature sensors, the Vertical Lossnay unit automatically enters Bypass Mode when it detects a space is hotter than desired and the outside air is cooler.

To reduce the risk of overheating the home, fresh air is introduced, bypassing the Lossnay Core. This is ideal for cooling down a dwelling that may have overheated during the day once the outside temperature has dropped in the evening.

## Easy to Use Control

A built-in LCD controller allows for easy control and commissioning of the unit. This interface displays all functionality, temperature settings of the system.

## Slimline to Fit in a Cupboard

The vertical upright design of the Lossnay Ventilation System is not limited to an in-roof installation. Now whole home ventilation can be integrated into the overall building design without limitations.



Model	Width (mm)	Depth (mm)	Height (mm)	Weight (kg)
VL-250	595	356	565	26
VL-350	658	432	623	32
VL-500	725	556	632	39

Available in Left and Right Hand Options



# Fresh Air Heat Recovery Ventilation

## Lossnay is Designed for Today's Modern Homes

---

The word "Lossnay" originated from the Japanese word "Loss-Nai", meaning "No Loss". Lossnay is a patented Balanced Pressure Heat Recovery Ventilation System ideal for more airtight homes built to the current New Zealand Building Code. Using Lossnay Ventilation Systems can achieve compliance with the Ventilation Standard NZS4303:1990 that specifically requires ventilation systems to draw fresh air from the outside and not the roof space to achieve acceptable indoor air quality.

## Ventilation and Airtight Building Design

---

Creating a healthy living environment is important when renovating or building a new home – you will want the perfect indoor climate year-round. In addition to efficient heating and cooling, this should include the optimum amount of fresh air.

Current building regulations now demand homes to be built more airtight as they are subjected to higher insulation standards. The option of leaving doors or windows open to allow more fresh air to enter is often not the solution from an outdoor noise or security perspective.

## Ventilation, Condensation and Moisture Management

---

The lack of natural ventilation due to airtight spaces can lead to the build-up of moisture-laden stale air within the home and creates the perfect breeding ground for mould that can trigger allergy or respiratory problems. Mould and dampness can compromise both building materials as well as furnishings inside the home. Common places for mould to grow include window sills, curtains and carpets.

## Advanced Filtration for Better Health and Wellbeing

---

The quality of indoor air is an important factor for health and wellbeing and the new Vertical Lossnay Range ensures there is a constant flow of fresh air into our homes, and that potentially harmful pollutants and chemicals are being removed at the same time.

The new residential range comes with optional NOx (nitrogen oxide) and Particulate Matter Filtration, with a unique third filter pocket which can be used for additional filtration of NOx emissions.

This means that homes in even the most polluted environments can be supplied with clean, healthy air. Furthermore, the inbuilt filters are easily accessible for regular maintenance.

## Energy Efficient Operation

---

Ventilating our indoor spaces is more important than ever, but we also need to be as energy efficient as possible. The new Vertical Lossnay will deliver filtered indoor air whilst recovering energy to minimise waste.

Infact, Lossnay's unique heat recovery technology recovers up to 85% of the heat energy from the outgoing stale air which is then used to pre-warm incoming fresh air.



# The Lossnay Difference

Ventilating your home is vital as it maintains air quality and reduces moisture, creating a healthier and more comfortable environment. The Mitsubishi Electric Lossnay System is a patented heat recovery ventilation solution that uses fresh air (not attic air) to ventilate your home. The system works by extracting stale air from inside your house and replacing it with allergen-reduced fresh air from outside.

Furthermore, Lossnay also recovers heat energy from the outgoing stale air to pre-warm (or pre-cool) the fresh air being drawn into your home.



## Improved Air Quality

By drawing in fresh outdoor air, indoor air quality is improved as high levels of CO<sub>2</sub>, odours and other pollutants are removed from your home.



## Fresh Air Without Open Windows

Lossnay allows you to have a well-ventilated home without the need to open windows. This improves the safety of your home and family and means outdoor noise is minimised.



## Retains Heat

Lossnay's unique Heat Recovery Technology recovers up to 85% of the heat energy in outgoing air which is then used to pre-warm or cool the incoming fresh air.



## Balanced Pressure, No Draughts

Lossnay is specifically designed for more airtight homes built to the current New Zealand Building Code; delivering the optimum amount of fresh air without creating draughts and minimising indoor temperature fluctuations.



## Whisper Quiet Operation

From an ultra quiet 15dB\*, the Vertical Lossnay is the ideal solution for residential homes and apartments where comfort is key.

\*On fan speed 1. Sound pressure level at 3m.

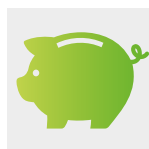

## Energy Efficient

Boasting an A+ efficiency rating, incoming fresh air is pre-warmed so your heating system isn't required to work as hard to reach a desired temperature. This is highly energy efficient, and can help reduce heating bills.



## Creates a Healthier Home

Filtered fresh air improves air quality for allergy and asthma sufferers.



## Assists with Moisture and Condensation Control

Effectively reduces moisture in your home by directly removing stale air that causes condensation.



## Easy Control At Your Finger Tips

An intuitive controller with easy-to-read LCD display comes mounted as standard. Fan speed, night set back and 24-hour and weekly timers can easily be customised and programmed with multiple stop and start patterns per day.



## Easy To Clean

The standard filters can be removed for regular cleaning to keep the unit in optimal working condition.

## Why Outside Air, Not Attic Air?

Not all air is created equal. Lossnay only draws fresh air from the outside – it does not draw air from the attic.

The absence of significant air movement common in attics means the air is likely to be stale. In addition, build-up of dust, dirt and other contaminants such as mould, insect and rodent droppings makes this air much harder to filter before it is distributed through your home.

This is why the Balanced Pressure Lossnay System specifically utilises direct fresh air instead.



## The Lossnay Core

The Balanced Pressure Lossnay Heat Recovery Ventilation System removes stale, dirty air and draws in fresh air from outside. Lossnay also recovers heat energy from the air being transferred to pre-warm (or pre-cool) the fresh air being drawn into your home. Lossnay is ideal for small to large sized homes between 52m<sup>2</sup> and 400m<sup>2</sup>.

- RA** The stale air extracted from your home is Return Air (RA). Return Air can contain high levels of CO<sub>2</sub>, odours and other pollutants. This Return Air stream also contains heat energy that Lossnay can recover, which is not the case with positive pressure ventilation systems.
- EA** As the stale Return Air is removed, the Lossnay Core 'recovers' the useful heat energy from it. The air is then exhausted (EA) outside along with the unwanted pollutants.
- OA** Outdoor Air (OA) is introduced to provide fresh air. It is first filtered, then passed through the Lossnay Core. This allows it to be pre-heated in winter (or pre-cooled in summer) using the energy recovered from the Return Air.
- SA** Supply Air (SA) then enters your house as fresh pre-heated or pre-cooled air.

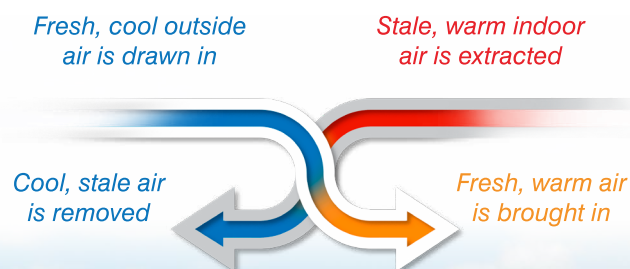
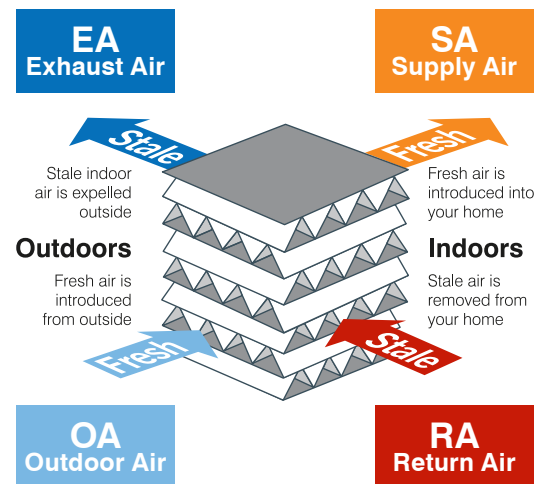

# Specifications

Model	VL-250CZPVU-L/R-E				
Electrical Power Supply	220-240V / 50Hz				
Ventilation Mode	Heat Recovery Mode				
Heat Exchanger Type	Sensible Heat Exchanger				
Fan Speed	FS4 (100%)	FS3 (70%)	FS2 (50%)	FS1 (30%)	
Running Current	A	0.76	0.35	0.20	0.12
Input Power	W	106	44	23	11
Air Flow	m <sup>3</sup> /h	250	175	125	75
	L/s	69	49	35	21
External Static Pressure	Pa	150	74	38	14
Temperature Exchange Efficiency	%	85	87	88	90
Sound Pressure Level at 3m	dB	31	22	16	15>
Energy Efficiency Class (ErP)	A+				
Weight	kg	26			
Dimensions (HxWxD)	mm	565x595x356			

VL-250CZPVU-L/R-E Performance Characteristic Curve

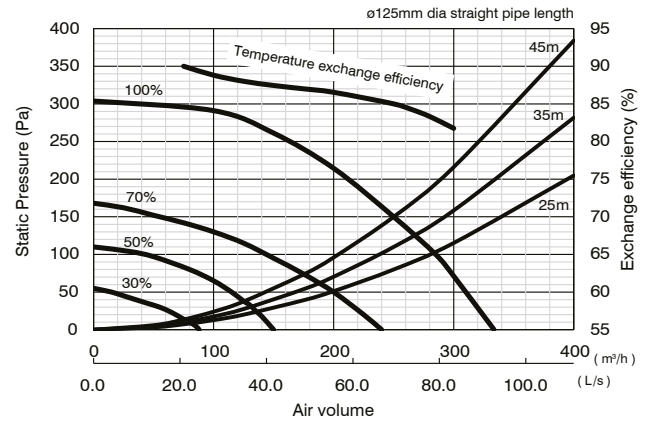

## VL-250CZPVU-L-E

Left sided Outdoor Air (OA) and Exhaust Air (EA) connections

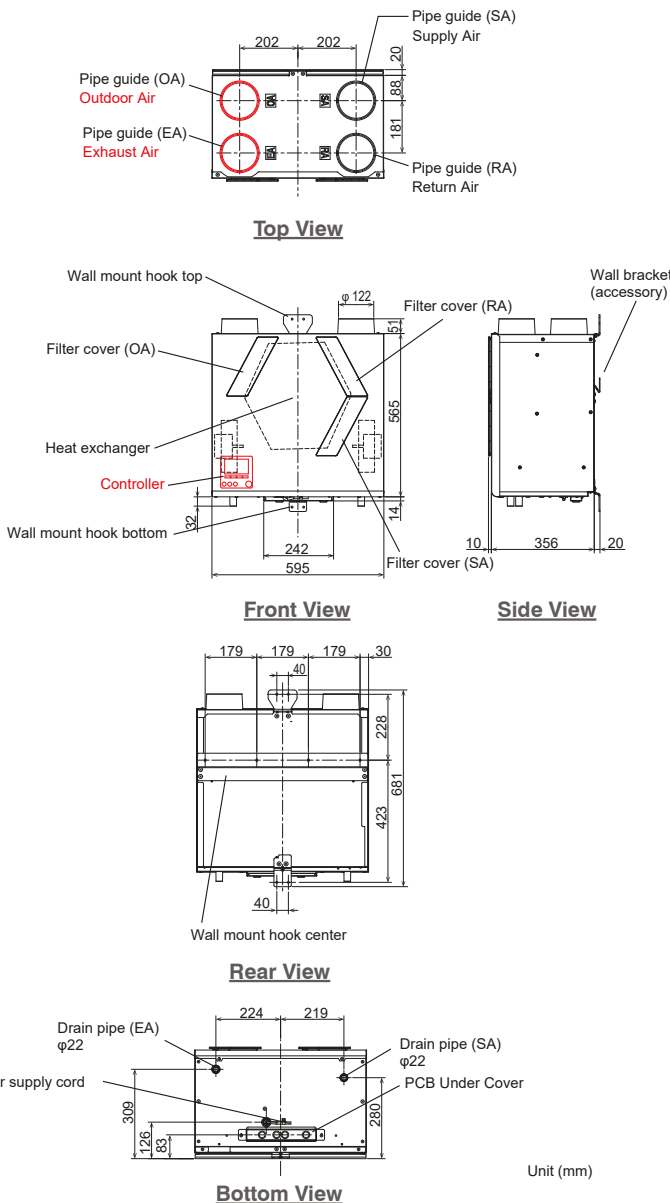

## VL-250CZPVU-R-E

Right sided Outdoor Air (OA) and Exhaust Air (EA) connections

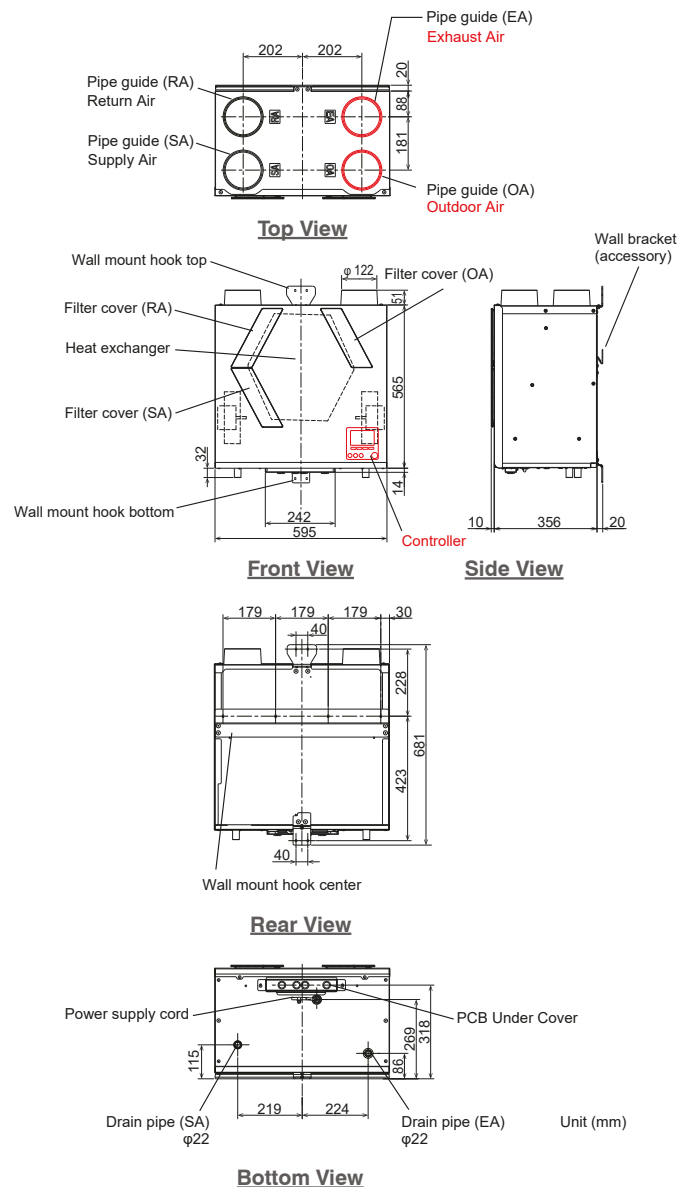

Model	VL-350CZPVU-L/R-E				
Electrical Power Supply	220-240V / 50Hz				
Ventilation Mode	Heat Recovery Mode				
Heat Exchanger Type	Sensible Heat Exchanger				
Fan Speed	FS4 (100%)	FS3 (70%)	FS2 (50%)	FS1 (30%)	
Running Current	A	1.08	0.52	0.31	0.18
Input Power	W	155	71	37	19
Air Flow	m <sup>3</sup> /h	320	224	160	96
	L/s	89	62	44	27
External Static Pressure	Pa	150	74	38	14
Temperature Exchange Efficiency	%	85	87	88	90
Sound Pressure Level at 3m	dB	35	26	19	15 >
Energy Efficiency Class (ERP)	A+				
Weight	kg	32			
Dimensions (HxWxD)	mm	623x658x432			

VL-350CZPVU-L/R-E Performance Characteristic Curve

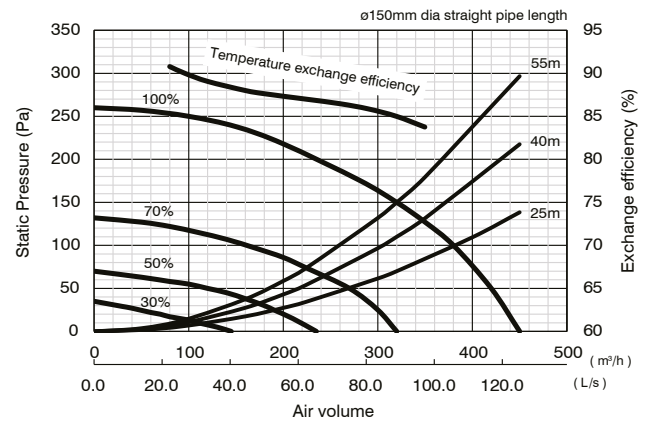

### VL-350CZPVU-L-E

Left sided Outdoor Air (OA) and Exhaust Air (EA) connections

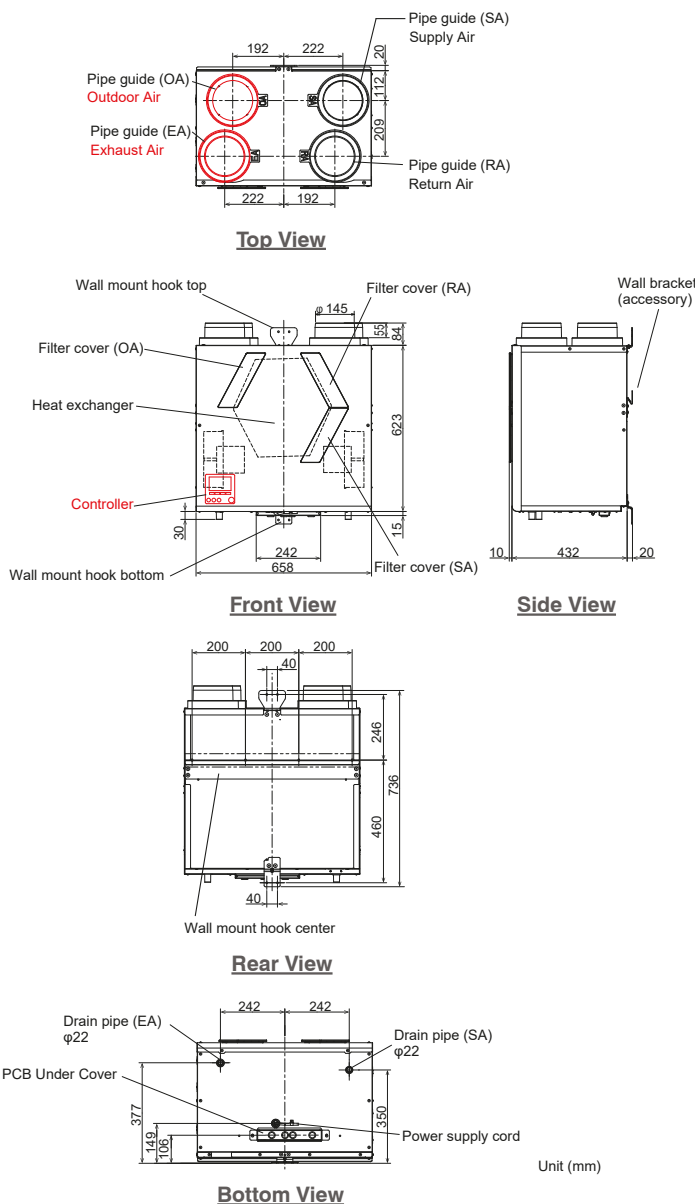

### VL-350CZPVU-R-E

Right sided Outdoor Air (OA) and Exhaust Air (EA) connections

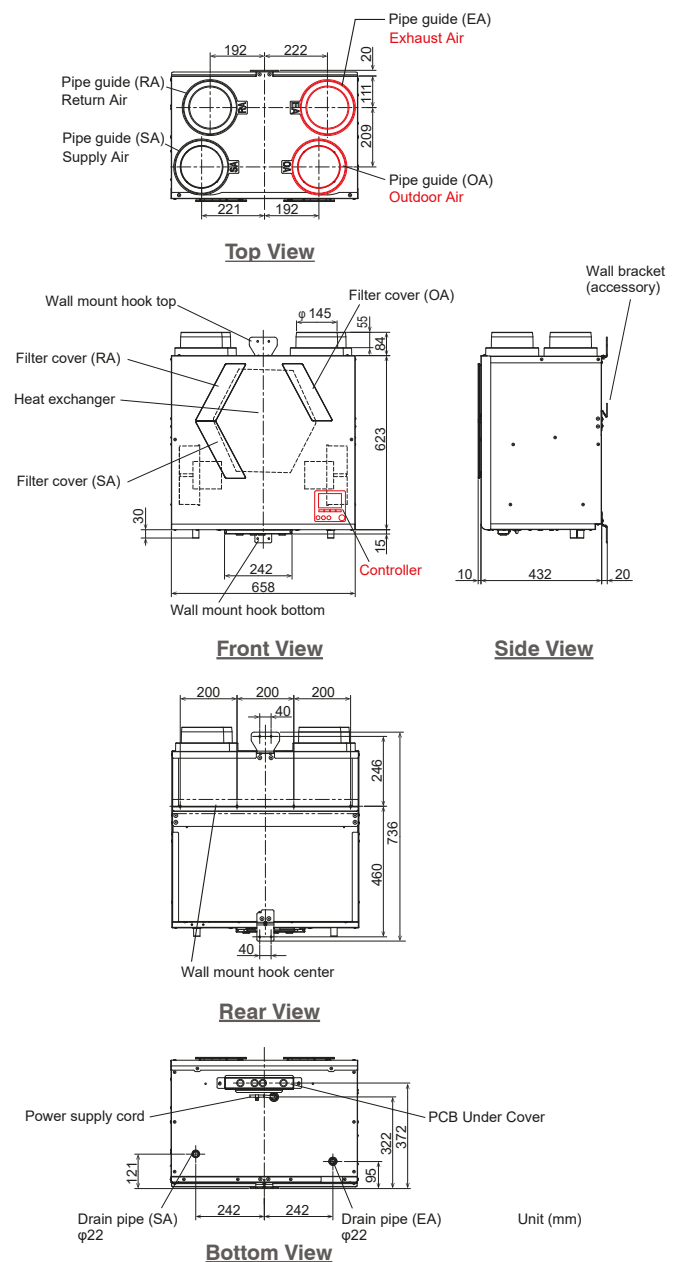

Model	VL-500CZPVU-L/R-E				
Electrical Power Supply	220-240V / 50Hz, 220V / 60Hz				
Ventilation Mode	Heat Recovery Mode				
Heat Exchanger Type	Sensible Heat Exchanger				
Fan Speed	FS4 (100%)	FS3 (70%)	FS2 (50%)	FS1 (30%)	
Running Current	A	1.73	0.77	0.40	0.19
Input Power	W	275	104	49	21
Air Flow	m <sup>3</sup> /h	500	350	250	150
	L/s	139	97	69	42
External Static Pressure	Pa	200	98	50	18
Temperature Exchange Efficiency	%	85	87	89	92
Sound Pressure Level at 3m	dB	37	29	22	15>
Energy Efficiency Class (ErP)	A+				
Weight	kg	39			
Dimensions (HxWxD)	mm	632x725x556			

## VL-500CZPVU-L/R-E Performance Characteristic Curve

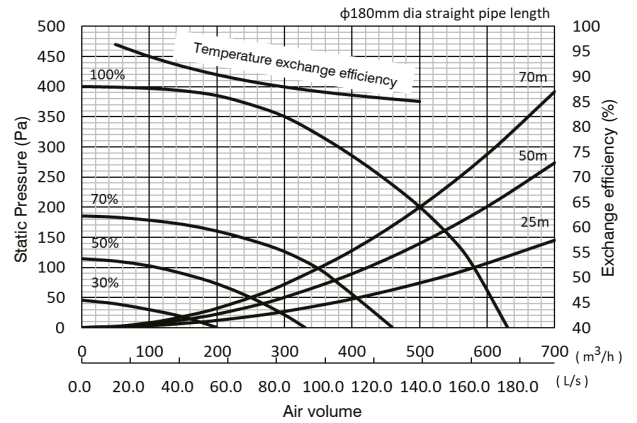

### VL-500CZPVU-L-E

Left sided Outdoor Air (OA) and Exhaust Air (EA) connections

### VL-500CZPVU-R-E

Right sided Outdoor Air (OA) and Exhaust Air (EA) connections

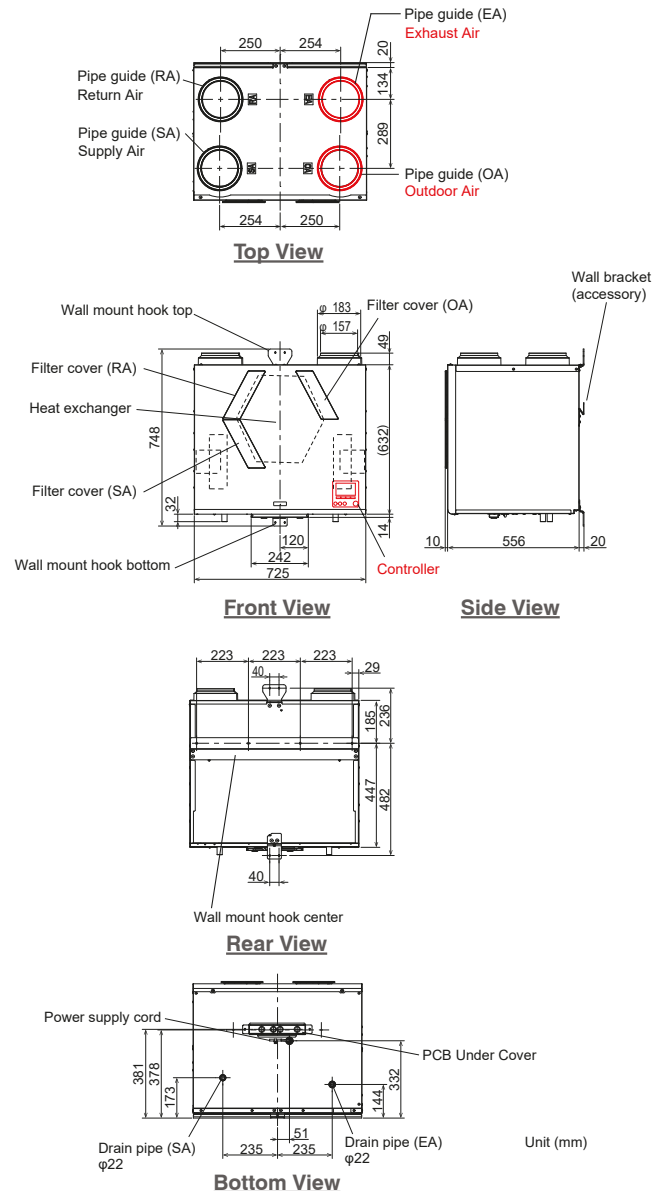
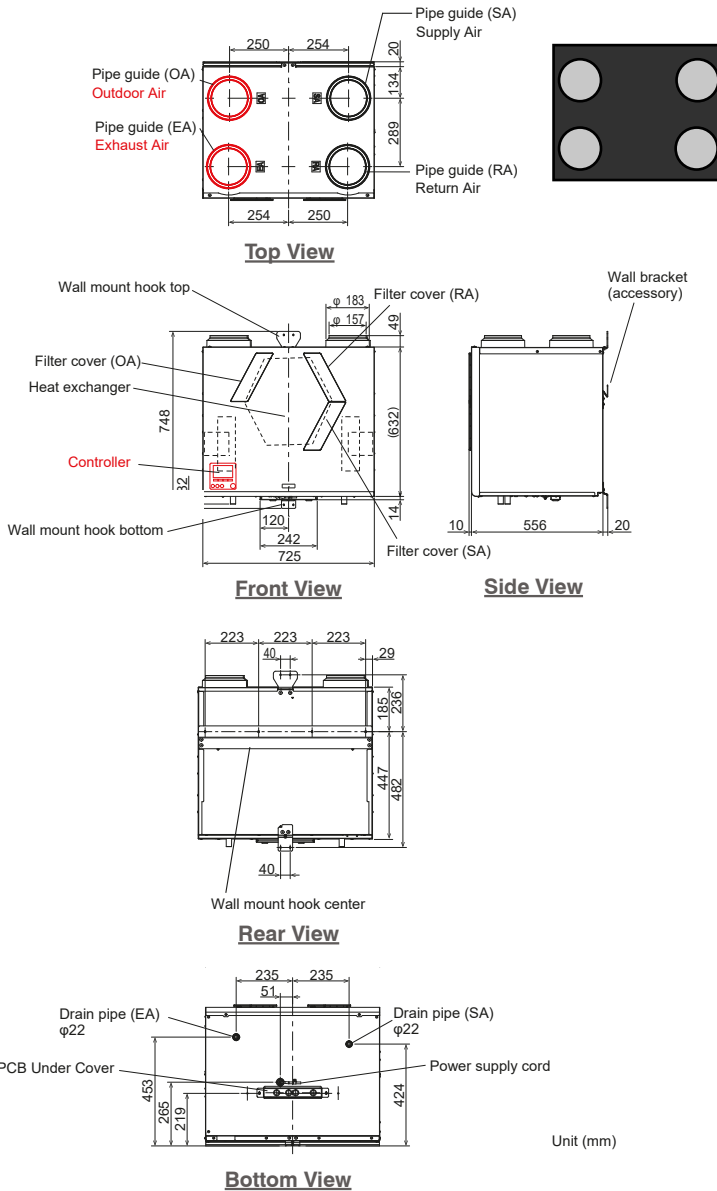

Black Diamond  
Technologies Limited



Exclusive New Zealand  
Partner Since 1981



For more information please visit our website or call our Customer Service Team.

[www.mitsubishi-electric.co.nz](http://www.mitsubishi-electric.co.nz) | 0800 784 382

PRINTED OCT 2021